



## **SARL Class B Amateur Radio License Study Guide**

Version 1.03 May 2016

This study guide has been compiled and written for the South African Radio League youth educational programme by Noel Hammond ZR6DX, and the “Class B Study Guide Workgroup” which consisted of the following contributors: John Brock ZS6WL; Neville Busse ZS6BN; Nick Dreyer ZS6NCK; Nic van Duffelen ZR6AEZ; Graham Busse ZS6GL and Nico van Rensburg ZS6QL.

This manual could not have been compiled without the help and support of the Class B Study Guide workgroup, to whom I am most grateful.

This Study Guide may only be used for non-profit educational purposes, and may not be copied or distributed for financial gain whatsoever. Clubs or organisations may however recover any printing costs where necessary.

The copyright of all the material herein, besides the graphic material, is held by the SARL, unless stated to the contrary.

This Study Guide is intended for any person under the age of 20, wishing to study towards obtaining a “Class B” amateur radio licence. The (ZU) or “Class B” licence is not CEPT certified; therefore the candidate will not receive a Harmonised Amateur Radio Examination Certificate (HAREC). This means the Class B licence holder may only operate an Amateur Radio Station within the borders of South Africa, with limited band and power privileges.

The examination will be conducted using multiple choice questions. This will consist of two parts. Part one: 20 regulation and operating procedure questions. Part 2: 10 technical questions. Candidates must achieve 50% in each section and an overall 65% to pass. Each candidate will also need to complete an HF assessment, which covers operating procedure and the setting up of an amateur radio station. This will be completed in the form of practical exercises during the course.

## Table of Contents

<b>Introduction</b>	Page 3
<b>Chapter 1</b> Operating procedure and practice	Page 5
<b>Chapter 2</b> Repeaters VHF and UHF	Page 12
<b>Chapter 3</b> Co-ordinated Universal Time (UTC)	Page 15
<b>Chapter 4</b> Electrical Safety	Page 16
<b>Chapter 5</b> Basic Electronics	Page 21
<b>Chapter 6</b> Radio communication principles	Page 33
<b>Chapter 7</b> Antennas	Page 38
<b>Chapter 8</b> Propagation	Page 42
<b>Chapter 9</b> Electromagnetic compatibility and interference	Page 44

## Introduction

### What is Amateur Radio?

Amateur radio is one of the few hobbies in the world that is regulated by international and national regulations. The international regulating body is the International Telecommunications Union (ITU), which also allocates radio spectrum and satellite orbits. Membership of ITU consists of 193 countries and over 800 private sector companies, with headquarters situated in Geneva, Switzerland. In South Africa, the national regulator is ICASA - The Independent Communications Authority of South Africa. ICASA falls under the auspices of the minister of Postal and Telecommunications.

ICASA in conjunction with ITU have allocated amateur radio operators twenty six frequency bands, with each band having a set frequency range. Methods of transmission are also specified by ICASA. Therefore, it is necessary for the candidate to know and understand the regulations pertaining to these allocations, and the reason for writing an examination approved by ICASA. The candidate may then apply for a call-sign, once the examination has been passed, and may operate as a Class B license holder.

There are many facets to Amateur Radio which may appeal to individuals, for example:.

#### **1. Emergency communications**

When disaster strikes and the normal communication networks are unable to function, it is often possible to use Amateur Radio communications. These operators are able to assist emergency and disaster management teams. In South Africa we have an organisation called HAMNET, which is the National Emergency Communications division of the South African Radio League (SARL). HAMNET play a valuable role in providing communication services during disasters and emergencies.

#### **2. Volunteer and public communications**

Amateur Radio operators are able to provide communications for events like cycle races and car rallies, as big distances may have to be covered.

#### **3. Technical hobbies and interests**

Amateur Radio provides a platform for the enjoyment of other hobbies like electronics and computer technology. Opportunities are also afforded to the Amateur Radio operator to experiment with radio, to explore astronomy, collect antique radios, learn radio repair and experiment with antenna technology etc.

#### **4. Taking part in contests**

International and local contests take place most weekends, whereby the objective is to make as many contacts with other radio operators as possible. Groups and individuals may take part, and this often provides fun and stimulates competitiveness.

#### **5. Social networks**

Many daily and weekly networks are established, where operators get together and engage socially to share their knowledge of Amateur Radio, or just for a “rag chew”.

# Chapter 1

## Operating Procedures and Practice.

### 1 Call Signs

Amateur Radio call signs are allocated to individuals, clubs or contest stations by ICASA. These call signs are used to legally identify the country, area and person or club. Call signs are broken up into a prefix (beginning) and a suffix (ending).

The first part of the prefix is allocated by the ITU (International Telecommunications Union) to a specific country or entity. For South Africa, the prefixes are as follows: ZR, ZS, ZT, and ZU. Therefore, these prefixes designate South Africa. The second part of the prefix is a number which designates the area or division that the operator lives in.

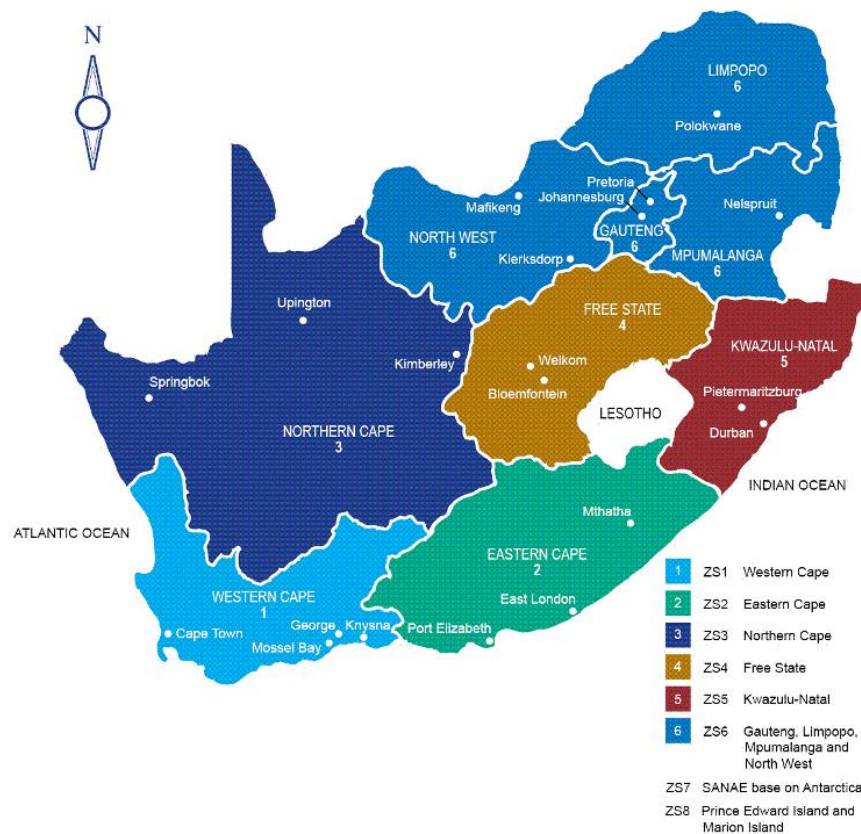

#### 1.2 Divisions are as follows:

- Division 1            Western Cape
- Division 2            Eastern Cape
- Division 3            Northern Cape
- Division 4            Free State
- Division 5            KwaZulu Natal
- Division 6            Gauteng, Northwest, Limpopo and Mpumalanga

The suffix can be one, two or three letters. These letters then identify the licensed operator. Sometimes, the numbers and letters can be more, but is normally only used for special events or occasions.

Let's look at the call sign ZS6ZU.

## ZS6ZU

ZS6 = prefix

The first two letters of the prefix designate the country and the number designates the location area of the station.

ZU = suffix

The suffix or last one, two or three letters designate the licensed operator.

So now we can identify that the person is from South Africa, lives in region 6 and by the suffix, we can identify the licensed operator.

The ZU prefix indicates the operator is licensed as a Class B foundation operator, which is a restricted license.

When working in another division or area, you should always indicate the division after your call sign. As an example;

If ZS6ZU was operating in KwaZulu Natal then they would call "Zulu Sierra Six Zulu Uniform Division Five" written as ZS6ZU/5.

## 2 Phonetic Alphabet

The phonetic alphabet, also known as the 'spelling alphabet' is used by communicators to identify letters precisely, or for abbreviations or spelling of words. This is a universal alphabet used by all Amateur Radio operators.

A	Alpha	AL fah	N	November	No VEM ber
B	Bravo	BRA voh	O	Oscar	OSS cah
C	Charlie	CHAR lee	P	Papa	PAH PAH
D	Delta	DEL tah	Q	Quebec	Kwe BECK
E	Echo	Ekk oh	R	Romeo	ROW me OH
F	Foxtrot	FOKS trot	S	Sierra	See AIR rah
G	Golf	GOLF	T	Tango	TANG go
H	Hotel	Ho TELL	U	Uniform	YOU NEE FORM
I	India	In dee ah	V	Victor	VIK tah
J	Juliet	Ju lee ett	W	Whiskey	WISS key
K	Kilo	Kee loh	X	X-Ray	ECKS ray
L	Lima	LEE Mah	Y	Yankee	YANG KEY
M	Mike	Mike	Z	Zulu	ZOO loo

### 3 Q-Codes

The **Q-code** is a standard collection of three-letter message encodings, which start with the letter "Q". The Q-code was initially developed for commercial radiotelegraphy. Although Q-codes were created for Morse Code (CW), they were quickly adopted when voice transmission came into being. Each Q-code has a specific meaning and is an abbreviated way to exchange information. As a Class B candidate, you will be required to know the following Q-codes:

<b>Q-Code</b>	<b>Question</b>	<b>Answer</b>
QRM	Are you being interfered with?	I am being interfered with
QRN	Are you troubled by static?	I am troubled by static
QRP	Must I decrease power?	Decrease power
QRT	Must I stop transmission?	Stop transmission
QRZ	Who is calling me?	You are being called by.....
QSB	Are my signals fading?	Your signals are fading
QSL	Can you acknowledge receipt?	I am acknowledging receipt.
QSO	Can you communicate with ...	I can communicate with .....
QSY	Shall I change to another frequency	Change to another frequency
QTH	What is your location?	My location is .....

### 4 Short hand codes known as CW (Morse Code) abbreviations

CW abbreviations or short hand codes have also been adopted by Amateur Radio operators for voice operation. As a Class B candidate, you will be required to know the following short hand codes:

<b>Code</b>	<b>Meaning</b>
CQ	Calling any station
DX	Distance, foreign countries
OM	Old Man (used when you don't know the operator's name)
YL	Young Lady
XYL	Wife
73	Best regards
88	Love and kisses
Hi	The telegraphic laugh...Hi Hi

## 5 RST System

The RST (Readability Strength Tone) is used by amateur radio operators to exchange information on the quality and strength of the received radio signal.

**R** (Readability) denotes how easy or difficult it is to correctly copy or hear the information received by the transmitting station and is measured in a scale of 1 to 5.

1. Unreadable
2. Barely readable, occasional words distinguishable
3. Readable with considerable difficulty
4. Readable with practically no difficulty
5. Perfectly readable



**S** (Strength) Strength is an assessment of how powerful the received signal is at the receiving location. This is measured on the S meter of the radio and is measured in a scale of 1 to 9.

1. Faint signal, barely perceptible
2. Very weak
3. Weak
4. Fair
5. Fairly good
6. Good
7. Moderately strong
8. Strong
9. Very strong signal

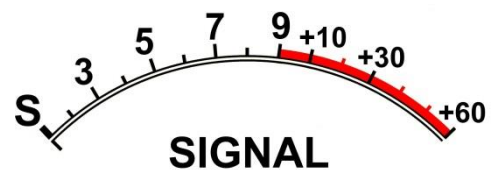

**T** (Tone) Tone is only used for Morse Code (CW), and is not required for a Class B licence.

## 6 Calling and Replying to a CQ

Before calling CQ, select a band and frequency that is unoccupied and listen for at least thirty seconds to one minute. If you don't hear any station or any one on air, go ahead and ask if the frequency is clear.

***Is this frequency in use, Zulu Sierra Six Zulu Uniform?***

Wait for 30 seconds or so and if you don't hear anything, go-ahead and call CQ to ask for a contact.

***CQ CQ CQ Zulu Sierra Six Zulu Uniform standing by***



Wait for 5 to 10 seconds and if there is no response, call again. If you have been calling for some time and don't receive a response, then this might indicate that the propagation and conditions are poor. Select another band and try again.

If you want to make a specific call, such as a long distance contact to a foreign country, then use the following:

***CQ DX CQ DX CQ DX Zulu Sierra Six Zulu Uniform standing by***

### **Replying to a CQ**

If you hear another station calling CQ and want to make a contact then check the following:

- 1) Listen to establish if it is a directional call
- 2) Make sure the operators are not working "split". i.e. transmitting on one frequency and listening on another.

For example, if you hear a station (ZS1XX), Zulu Sierra one X-ray X-ray calling CQ, and you want to initiate a contact with them, wait until they stop transmitting and then call

***Zulu Sierra One X-ray X-ray this is Zulu Sierra Six Zulu Uniform***

**Note:** always give the other stations call sign first and your call sign last.

After making the contact, the first things stations normally do are to exchange the following details:

- 1) Signal Report
- 2) Name
- 3) Location

If the other station hears your call they will come back to you and they could say:

***Zulu Sierra Six Zulu Uniform this is Zulu Sierra One X-ray X-ray, thanks for coming back to my call. My name is John, Juliet Oscar Hotel November, and my QTH is Bellville Cape Town. I will give you your signal report on the next over. Back to you Zulu Sierra Six Zulu Uniform from Zulu Sierra One X-ray X-ray***

You will generally go back and give the other station a signal report, your name and QTH as follows:

***Zulu Sierra One X-ray X-ray this is Zulu Sierra Six Zulu Uniform, your signal report is a five nine (59) my name is Peter, Papa Echo Tango Echo Romeo and my QTH is Randburg, back to you John, Zulu Sierra One X-ray X-ray from Zulu Sierra Six Zulu Uniform***

You could also discuss the following:

1. Radio equipment
2. Antenna
3. Power used
4. Weather

### **7. Signing off**

***Zulu Sierra One X-ray X-ray this is Zulu Sierra Six Zulu Uniform, thanks for the QSO, Seventy Three (73) Zulu Sierra One X-ray X-ray from Zulu Sierra Six Zulu Uniform***

#### **General notes:**

Once a contact has been established and you know each other's call signs, then you do not need to use the phonetic alphabet. You must give your call signs once per over.

Do not discuss religion, politics, use foul language or say nasty things about someone. Be polite at all times. Do not interfere with other QSOs, by tuning up on the frequency or keying the mike.

For a contact or QSO to be recognised, you only require two of the following:

- 1) Signal report RS(T)
- 2) Call Sign

It is also important to record the time in UTC, as well as the band and mode used.

### **8. Logging contacts**

According to ICASA regulations, all HF contacts need to be recorded, unless you are operating when you are mobile.

Today most amateur operators log all their contacts on a computer. Computerised logs are extremely easy to use, are very flexible and have many additional features. Traditional written logs are still sometimes used, especially when out in the field.

Well-kept logs will preserve your fondest memories for many years. It serves as a bookkeeping system when working towards Ham Radio awards, such as the South African Radio League WAZS award (Worked All ZS). For this award, you need to have a set number of confirmed contacts with each division and a total of a hundred QSL's. An international award would be a DXCC (confirmed contacts with a hundred different countries/entities).

Log entries should include all the following information:

- 1) The call sign of the station worked
- 2) The date and time of the QSO ( Must be UTC)
- 3) The frequency or band on which the QSO took place
- 4) The mode used to communicate
- 5) Power used
- 6) Sent signal report
- 7) Received signal report

Log entries could also include the following:

- 1) Name of the other operator
- 2) QTH of the other operator
- 3) General comments
- 4) Grid locator
- 5) Sent and received exchange data (used for contests).

There are many other entries that an Amateur Radio operator may want to include in a log.

### 9. Logging VHF and UHF

As most VHF and UHF contacts are done via a repeater, it is not necessary to log these contacts. However, if you are working simplex you could log your QSO's and use these contacts towards certain awards etc.

### Standard Log Sheet Sample

Station: ZS6ZU                      Antenna: Multiband Dipole  
 Location: Randburg                Radio: IC 718  
 Operator: Nathan

No.	Date	Time	Station	Signal		Frequency	Mode	Power	Name	Remarks
				Sent	RCVD					
1										
2										
3										
4										
5										
6										

### Contest Log Sample *Hammies ZS6 Sprint Log sheet example*

Call sign

ZS6ZU
-------

**No**    **Station**    **Time UTC**    **RST Sent**    **Sent Exchange**    **RST Rec**    **Received Exchange**    **Band/Mode**    **Comment**

1	ZS6GL	13:00	59	GP	59	GP	40/LSB	Graham
2	ZU6G	13:05	59	GP	59	GP	40/LSB	Glen
3	ZU6CM	13:08	59	GP	59	GP	40/LSB	Connor
4	ZS5MAX	13:12	55	GP	58	KN	40/LSB	Max
5	ZS1YT	13:15	58	GP	57	WC	40/LSB	Rassie

## Chapter 2

### Repeaters VHF and UHF

A **repeater** is a radio, which is normally situated on a high site that receives a signal on one frequency and rebroadcasts it on another higher frequency. Repeaters use FM (Frequency Modulation) for communication. The repeater is normally installed on high sites like water towers, high buildings and mountains. This extends the range of its users and allows them to communicate over longer distances.

The standard range of VHF is line of sight. In other words, you can talk as far as you can see if there are no buildings, mountains or trees etc. in the way.

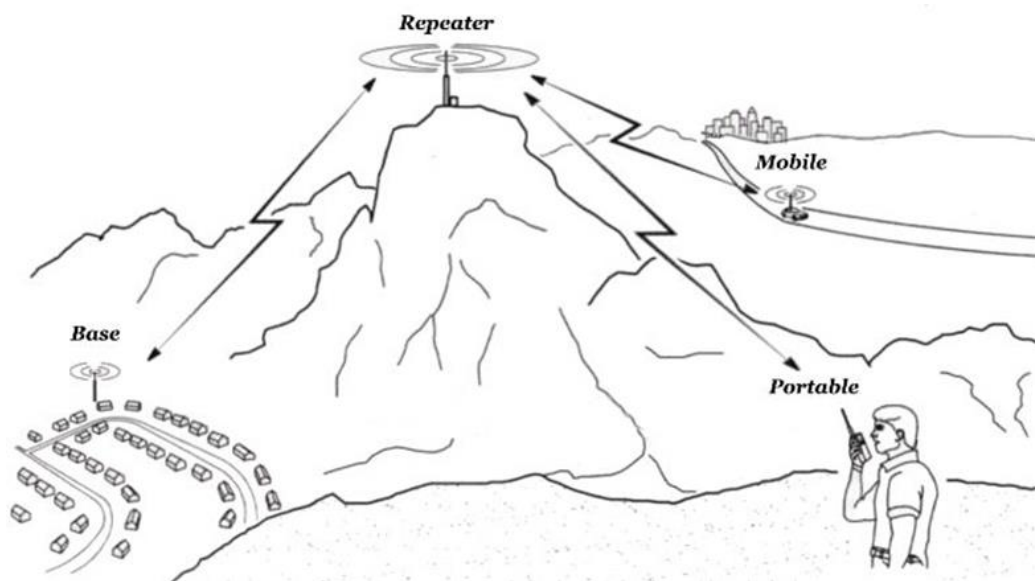

The repeater is keyed, when it receives a signal on its receive/input frequency. This signal will simultaneously be transmitted on the output/transmit frequency of the repeater. If you key a repeater there is generally a sound that is transmitted by the repeater, this is called the tail. The standard transmit and receive (TX/RX) offset frequency for VHF repeaters in South Africa is 600 kHz. Therefore, the repeater will transmit/TX the signal 600 kHz higher than the input/RX frequency. The channel spacing for VHF is 12,5 kHz and must be set to a "narrow" filter. For UHF (430 MHz) TX/RX the offset frequency is 7,6 MHz with a 25 kHz channel spacing. The filter must also be set to "wide". The UHF repeater will transmit/TX at a frequency of 7,6 MHz higher than the receive/RX frequency.

Some repeaters require a CTCSS tone (Continuous Tone Coded Squelch System) of 88,5 Hz to activate them. Without this tone, the repeater will not transmit the received signal.

## 1. Operating a repeater

QSO's or contacts on VHF or UHF repeaters are less formal than on HF. For instance, you do not have to call CQ. To make a contact on the repeater or to announce yourself, you could say the following:

***This is ZS6 Zulu Uniform, is there anyone on frequency?*** (Note: we have only used phonetics for the suffix.) Once we have made the contact, then we no longer need to use phonetics.

If a station is listening and wants to chat, he might reply as follows:

***ZS6ZU this is ZS6 Golf Lima. Hi there Peter good to hear you again, back to you ZS6ZU from ZS6GL***

From here onwards you would have a normal conversation, using the correct call sign sequence for each over.

Note:

- 1) You do not give a signal report as you only know the strength of the repeater output.
- 2) If asked for a report, you can indicate very loud, clear, hiss or signal raining, breaking up, sometimes referred to as flag waving, or audio low or soft.
- 3) Use minimum jargon and speak naturally.
- 4) Give your call sign every over.
- 5) Remember, repeaters are shared and not for exclusive, private use.
- 6) Change to a simplex frequency if possible, especially, if you wish to have a long conversation.
- 7) Long group chats are acceptable.
- 8) Leave a slight pause of between 2 to 3 seconds between each over. This gives someone else a chance to join in the conversation.
- 9) If you want to "break" into a conversation just give your "call sign".
- 10) Only use "Breaker Breaker" if there is an emergency situation.
- 11) Keep the overs fairly short, where possible.

## Working in groups

If working in a group, it is the acceptable norm to keep a sequence when handing it to the next person.

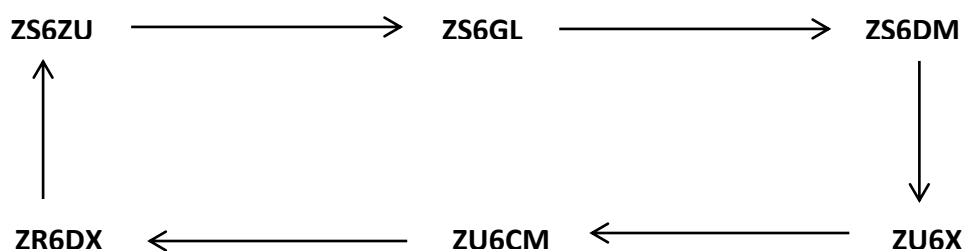

## Practical exercise (Lecturer)

### 1. Exercise one

Depending on the number of candidates, divide the students into groups, keep the groups to a minimum, and give each group a hand-held radio (Walkie Talkie). Set the radios to a simplex frequency and low power. Allocate the club call sign and your own call sign ( this should already be registered as an educational/training station ) to a group. Then under supervision, let them chat to each other using the correct protocol as laid out in this chapter. Make sure each student has a few chances to chat to their peers. Let the students talk about anything that they feel comfortable with e.g. their school, sport and hobbies. The main objective here is to get them to use the call signs in the correct sequence. Once they are confident move onto exercise two.

### 2) Exercise two

As per exercise one, use the same criteria, but this time let them spell out their names, using the phonetic alphabet.

### 3) Exercise three

As per exercise one and two, again use the same criteria, but this time, get them using a few Q-codes such as QTH, QSL etc. and giving a signal report to each other.

Once these exercises have been completed, go back to the lecture room and get the candidates to log the calls using the sample log supplied.

**Please note:** you should repeat these exercises until the candidates are comfortable using call signs, giving out signal reports and spelling out their names using the phonetic alphabet.

## Chapter 3

### UTC (Co-ordinated Universal Time)

UTC is the primary time standard by which the world regulates clocks and time. Keeping track of time can be very confusing. When working another station on the other side of the world, you need to know the exact time of the contact and the two times must correlate.

To be able to do this, the world is divided up into 24 different time zones from -12 hours to + 12 hours. Greenwich in England is on the prime Meridian Longitude and is universally recognised as the standard international time. This means that Greenwich, England, is half way around the world from the International Date Line.

This means if we use UTC and make a contact in Australia, we both know the exact time of the contact.

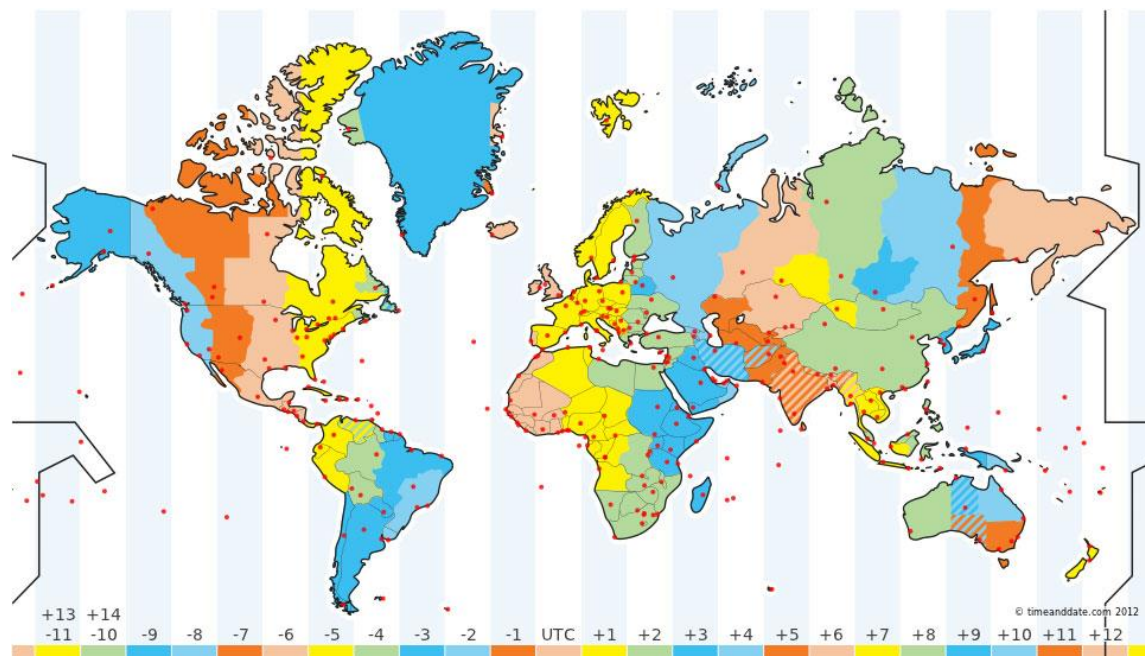

South African standard time is + 2 hours. So you need to subtract/minus 2 hours from the South African time to be able to get the time in UTC. If you were living in Australia you would have to subtract/minus anything from 8 to 10 hours from the local time.

## Chapter 4

### Electrical Safety

#### 1. Generation and distribution of electricity

Electricity is generated by huge electric generators that are powered by various means. In South Africa we have many coal powered power stations. We also have a nuclear power station that is situated in Koeberg, just outside Cape Town.

The electricity (Alternating Current) is distributed via extremely high voltage power lines to various points around the country. The voltage is stepped down using transformers before they reach our factories and houses.

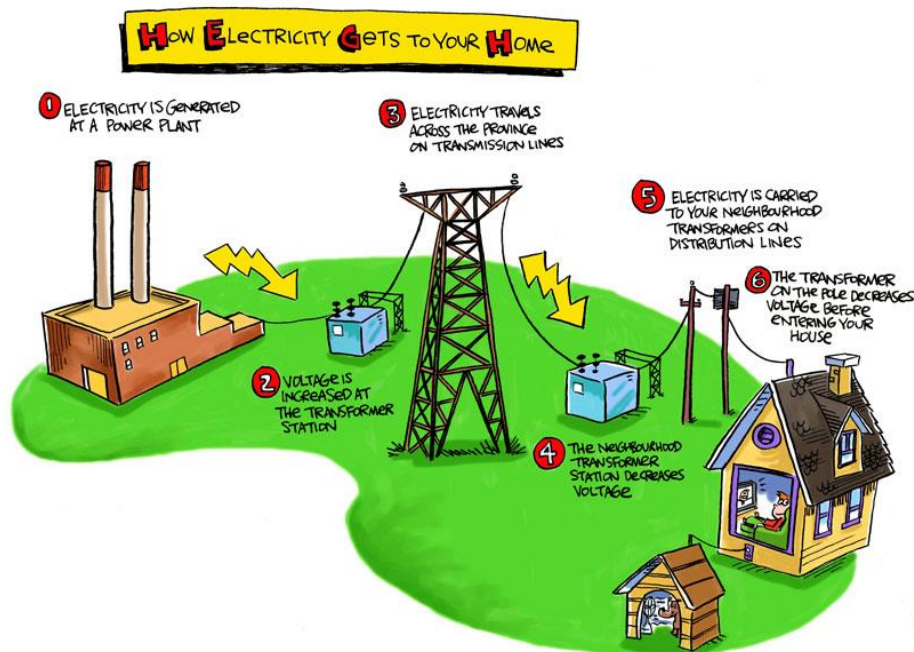

#### 2. Voltage and frequency

The mains voltage in South Africa is 230 Volts, at a frequency of 50 Hz.

#### 3. Safety

Electricity is extremely dangerous, and can cause serious injury or even death. When working with electricity, utmost care should be taken. You should never undertake any electrical work if you have not been trained to do so.



#### 4. Electrical safety around the home

Never overload an electrical supply point (plug) by adding adapters and then adding further appliances.

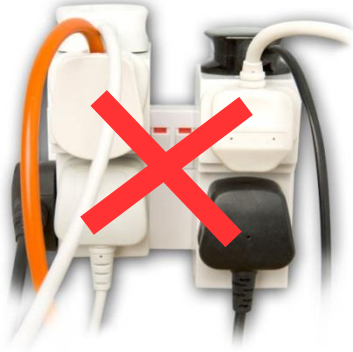

Know the limit!

$$5 + 5 + 3 = 13$$

AMP AMP AMP AMP

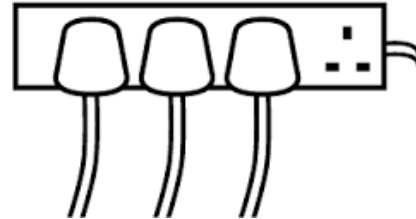

Use special adapter plugs, but know the current limit of each added appliance, so you do not overload the plug.

Overloading of plugs can lead to fire.

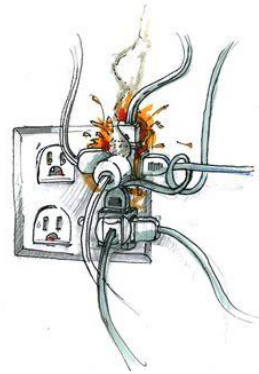

Never use electricity around water as water is a good conductor of electricity.



**5. It is important to conduct regular routine safety inspections around the home**

- a) Electrical equipment that needs repair should be attended to immediately.
- b) Breakages and wear and tear on electrical equipment can occur frequently.
- c) Check for loose connections.



- d) Check for signs of overheating. Overheating causes fires, so repair immediately.

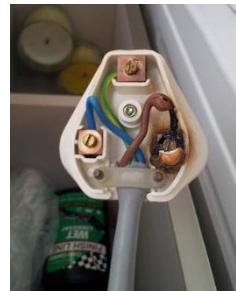
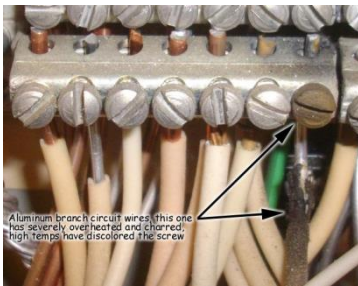

**Before working on or repairing electrical appliances or equipment, make sure that all electrical mains and/or the DC supply have been disconnected.**

**6. Wiring an electrical plug**

- 1) Expose the ends of the three wires inside the electrical cord for about half a centimetre by cutting away the plastic insulation.
- 2) Gently twist the strands of copper wire with your fingers until each strand is tight and fold them over.

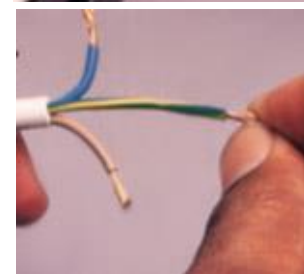
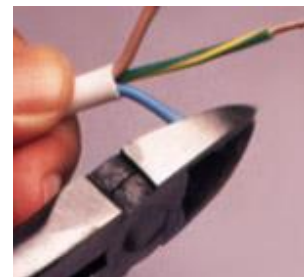

3) Remove the plug cover by unscrewing it.



4) Unscrew the little screws on each of the plug's pins.



5) Insert the twisted copper wires into the holes in the pins.  
The BROWN wire is inserted into the right pin (the pin is marked with a brown spot or the letter L).  
The BLUE wire is inserted into the left pin (the pin is marked with a blue spot or the letter N).  
The GREEN and YELLOW wire is inserted into the top pin.  
Make sure the earth wire is longer than the other wires.



6) Tighten the little screw on each of the plug's pins.



7) Make sure the electrical cord is firmly gripped by the arrestor clips.

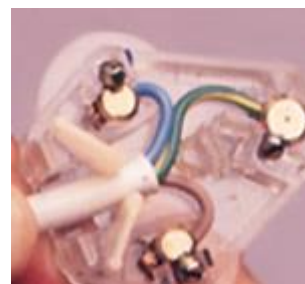

8) Replace the cover of the plug.



### Wiring Recap:

Brown wire = BR = Bottom Right..... **LIVE**  
Blue wire = BL = Bottom Left.....**NEUTRAL**  
Yellow Green wire = Top Pin.....**EARTH**

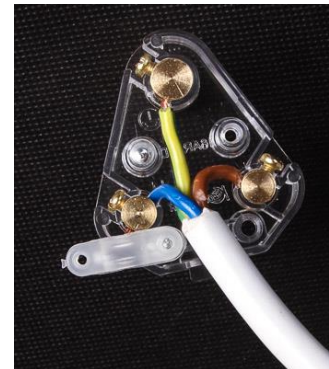
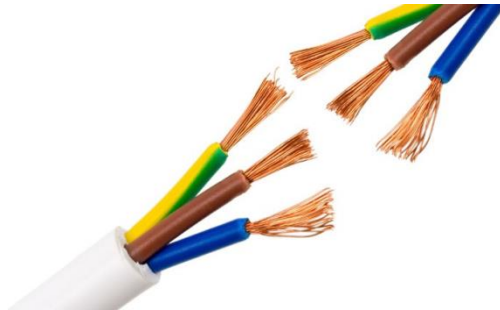

## 7. Electrical Earth

The electrical earth is a direct electrical connection to earth. An electrical earth connection consists of a ground rod, or a set of ground rods that are driven into the ground (soil). Electrical grounding is important because it provides a reference voltage level called ground potential. The electrical ground drains away any unwanted build-up of electricity. The earth has the ability to absorb or dissipate an unlimited amount of electrical charge.

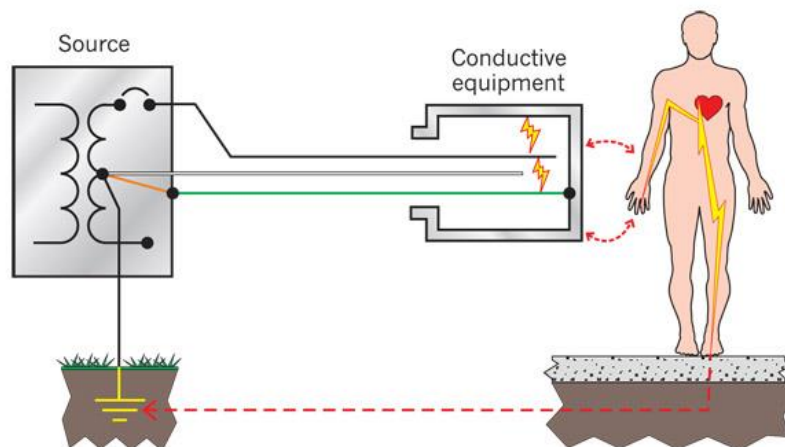

It's extremely important to earth all electrical appliances as this creates an electrical connection between the exposed metallic parts and earth. Proper earthing provides an easy path for leakage or faulty current to flow. It ensures that any metal part of an appliance does not reach a dangerous voltage level that can endanger the user's life.

### Practical Exercise. (Lecturer)

Each student must wire a plug top as per the above instructions.



## 2. Ohms Law

Ohms law is defined as: the electric potential (Volts) across a conductor is proportional to the current (Amps) flowing through the conductor.

**Ohm:** is the unit of measurement indicating the amount of resistance applied to the flow of current

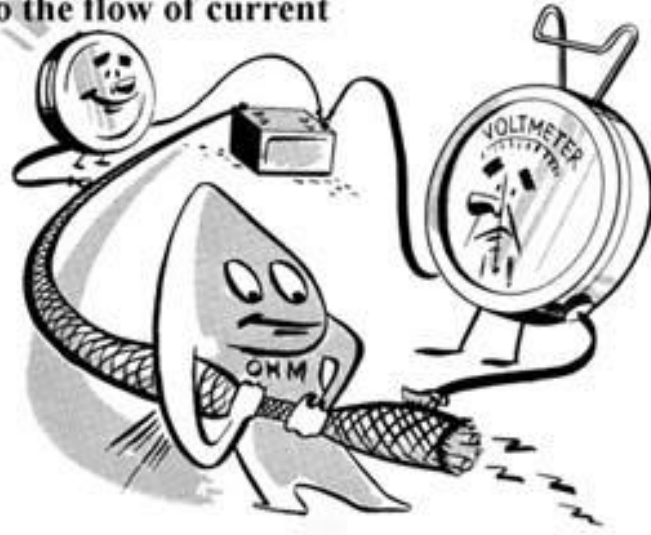

### Ohms law triangle

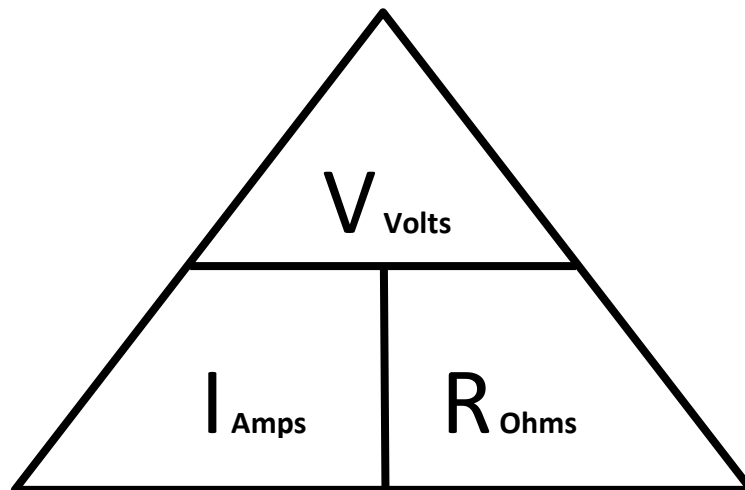

$$\text{Volts} = I \times R$$

### Ohms law continued

In simple terms, voltage is the amount of force, or pressure, (electrical potential energy) pushing the current (Amps) through the wires (conductor). Amps is the amount of current flowing through a conductor. Anything that resists the current flow is called a resistor and is measured in Ohms.



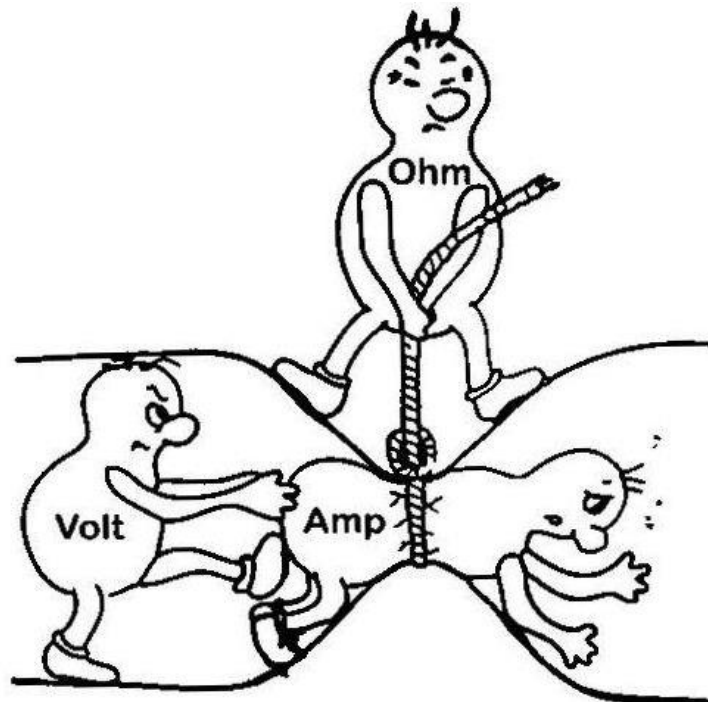

If we know the Voltage and the Resistance, we can calculate the Current. Note: we only need to know two of the values to calculate the other.

**Graphic examples of how to calculate each of the values**

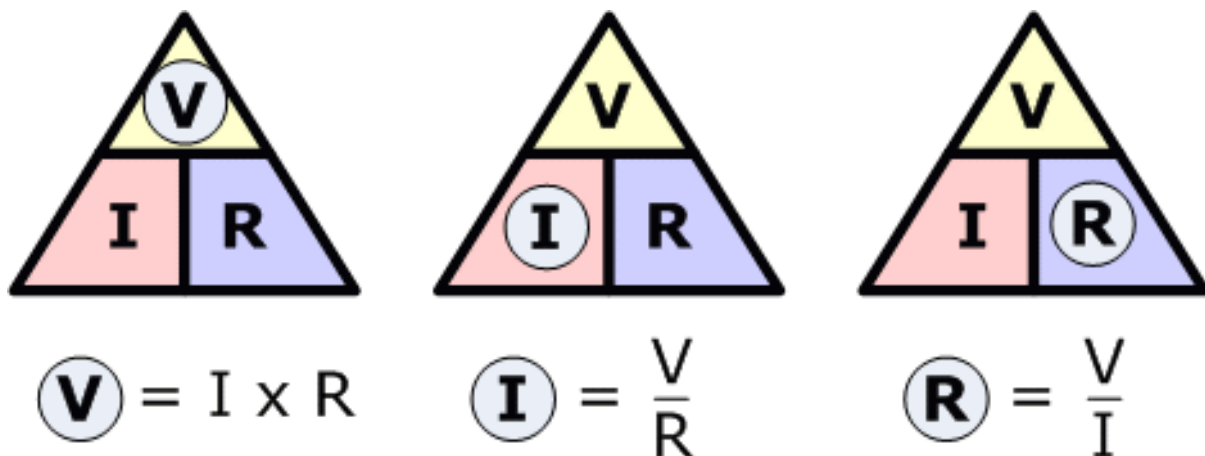

Notes to lecturer: Get the students to calculate a few examples of Voltage, current and resistance.

**3. Series and Parallel circuits**

There are two main ways to connect components together to make a circuit. These are called Series or Parallel circuits.

### 3.1 Series Circuits:

In a series circuit, there are no branches, and several components can be connected together, one after another on the wire. In a series circuit, if you remove one of the components, then the current will not flow. Typical circuit - Christmas tree lights

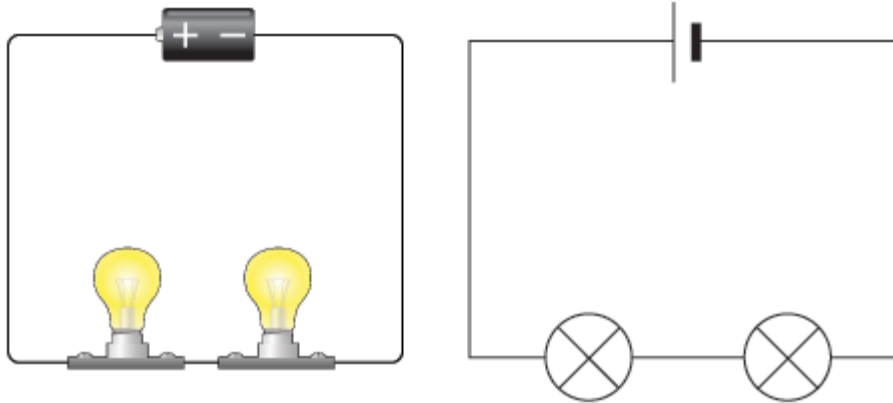

### 3.2 Parallel Circuits:

In parallel circuits, there can be many branches and components connected to different branches of the wire. In a parallel circuit, if you remove a component, the other components will still work.

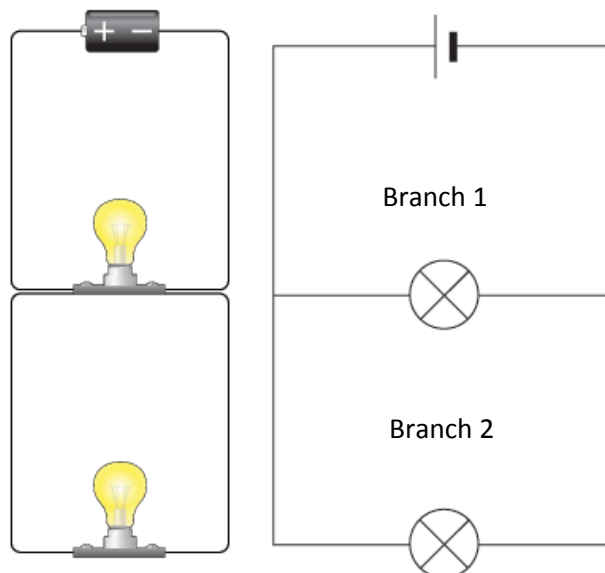

Notes to lecturer: Connect globes in a series and parallel circuit. Show what happens when removing the globes from each circuit.



## 4. Measuring Voltage and Amps (current)

### 4.1 Voltage:

We always measure volts in parallel and therefore we measure the volts across the component. This measures the electrical potential from one side of the component to the other side.

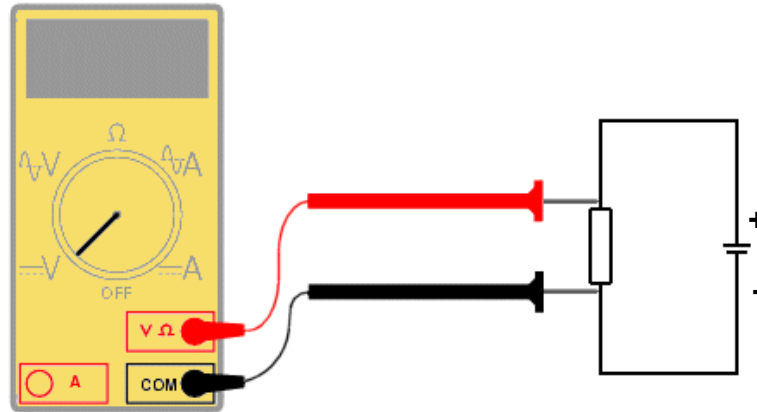

### 4.2 Current (Amps):

Always measure the current (amps) in series with the circuit. When measuring current flow (amps) the circuit is broken and the meter is placed in the circuit so the current flows through the meter.

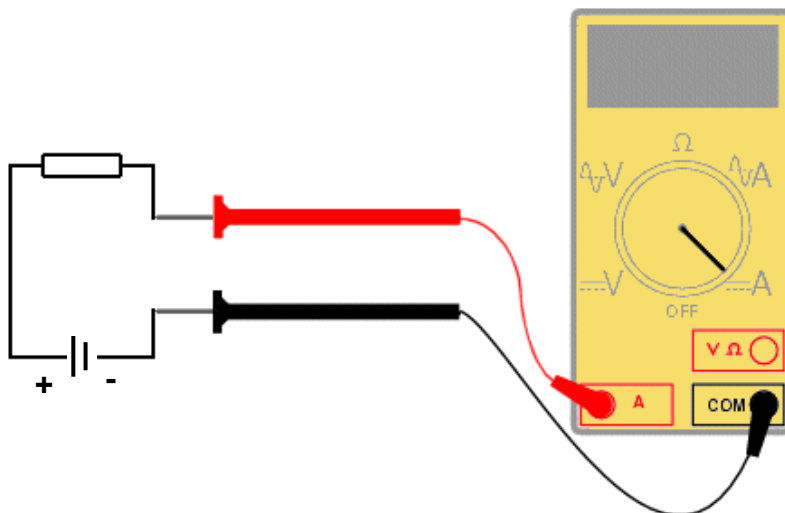

**Notes to lecturer:** Use a multi meter and get the students to measure the volts and amps, on the series and parallel globe circuit.

## 5. Resistors and Potentiometers

### 5.1 Resistors:

A resistor is an electrical component that limits or regulates the flow of electrical current (Amps) in an electrical or electronic circuit.

A Resistor is a passive component, and its main task is to reduce voltage and current (amps) in a circuit.

The current through a resistor is inversely proportional to its resistance and directly proportional to the voltage across it. (Ohms Law)

Resistors can be made in a variety of ways and from various materials, such as

*Carbon*

*Wire wound*

*Metal film*

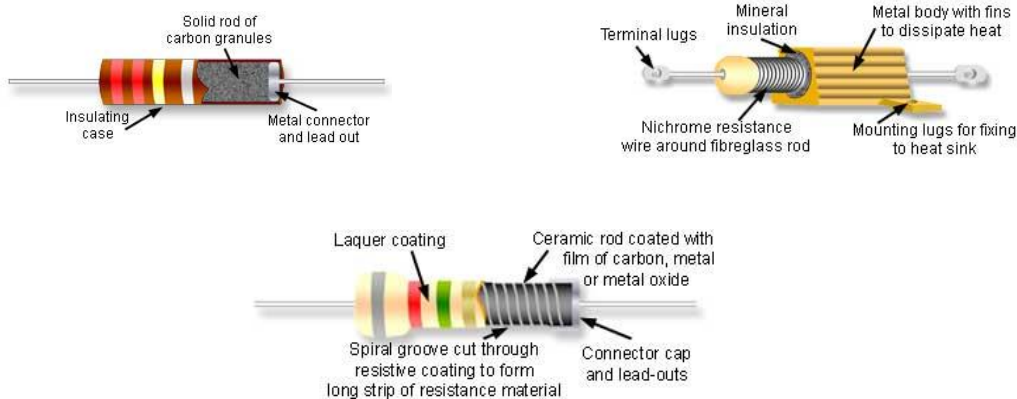

Colour codes on carbon resistors are used to identify the resistance value (ohms) of the resistor.

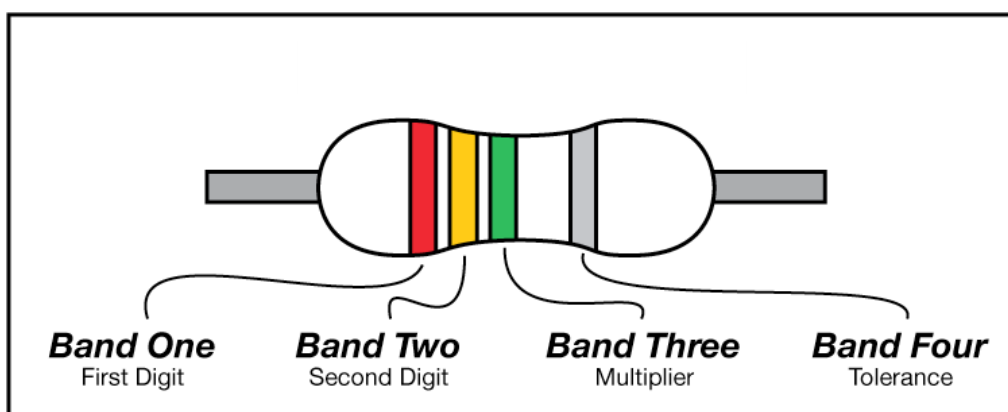

Resistors are also available in various power ratings such as,  $\frac{1}{4}$  watt,  $\frac{1}{2}$  watt, 1 watt, etc. The higher the power rating (watts), the more current (amps) they can handle.

## 5.2 Measuring resistance

When measuring resistance, the component must first be removed from the circuit. This ensures that other components, do not affect the reading. The meter probes are connected on either side of the component to read the value. The meter must be set to Ohms

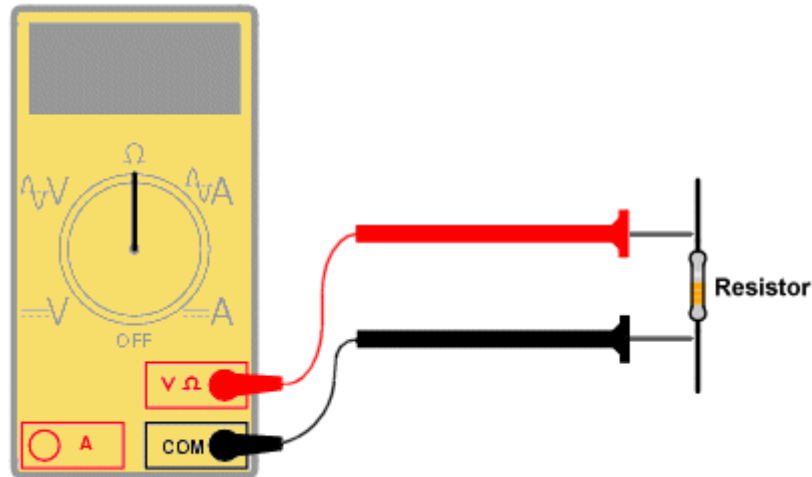

**Notes to lecturer:** Use a multi meter and get the students to measure a range of various resistors. Show the students colour codes, and a few different types and sizes of resistors.

## 5.3 Potentiometer

A potentiometer is a variable resistor. Typical construction is for the potentiometer or variable resistor to have three connections. There is a contact between the two fixed end connectors, called a wiper. This wiper is moved between the two end connectors, creating a variable resistance between itself and one of the end connectors.

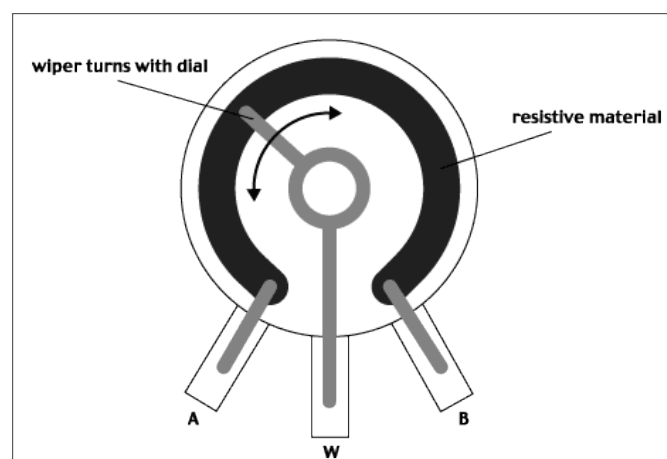

A and B are the fixed end connectors and W is the wiper.

**Notes to lecturer:** Insert a potentiometer in the series or parallel globe circuit and show the students what happens when the potentiometer is adjusted.

## 6. Alternating Current/Voltage and Direct Current/Voltage AC & DC

### AC

Alternating current/voltage is a flow of current or voltage that changes direction periodically. As a result, the voltage level also reverses along with the current. This period of change, happens 50 times or cycles per second. The current flows backward then forward. (Alternates)

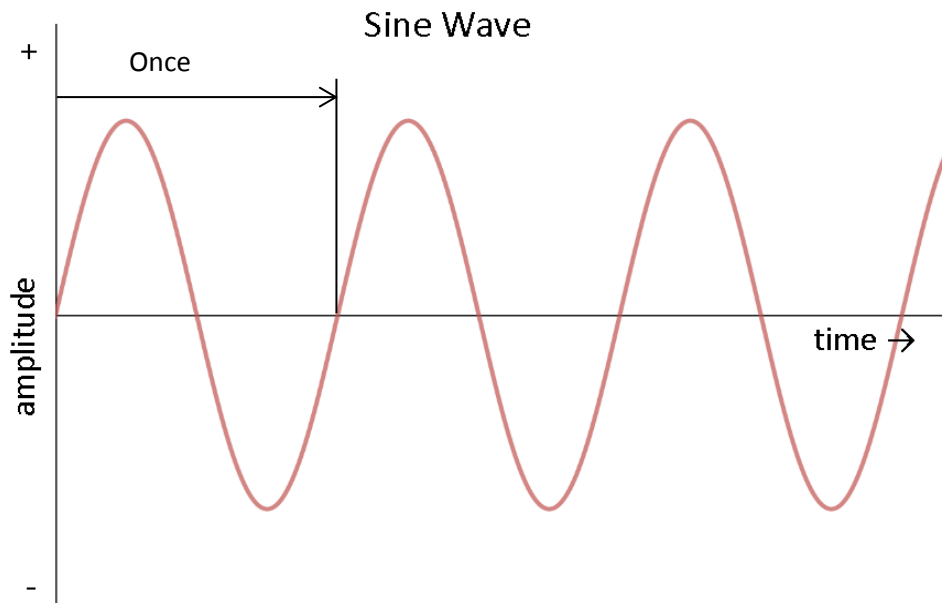

### DC

Direct current is defined as current that only flows in one direction and has a constant voltage. Batteries are a common source of DC. The current flows from negative (-) to Positive (+).

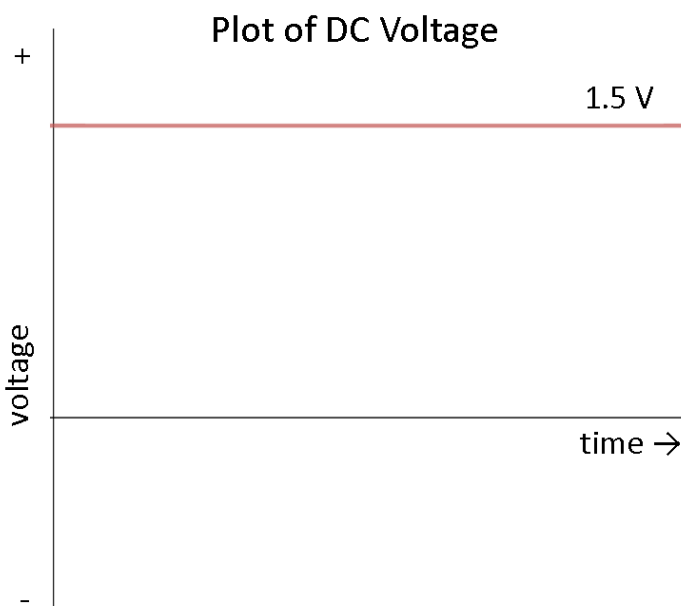

## 7. Insulators and Conductors

**Conductors** are materials that allow electrons to flow from one particle to another. (Allows electricity to flow).

Conductors are material such as; copper, aluminium, brass, gold, silver, iron, steel, carbon, and water.

**Insulators** are materials that stop electrons from flowing. (Stops electricity from flowing).

Insulators are material such as; plastic, rubber, paper, glass, dry air and wood.

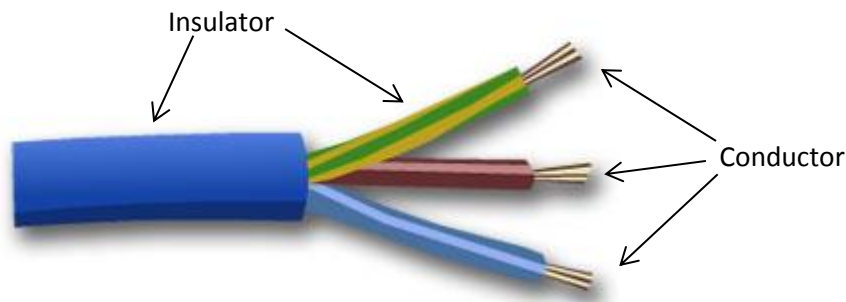

**Notes to lecturer:** Use the series or parallel circuit to show the difference between insulators and conductors. Also demonstrate that water is a conductor.

## 8. Diodes

A diode is a specialised electronic component that only allows current to flow in one direction.

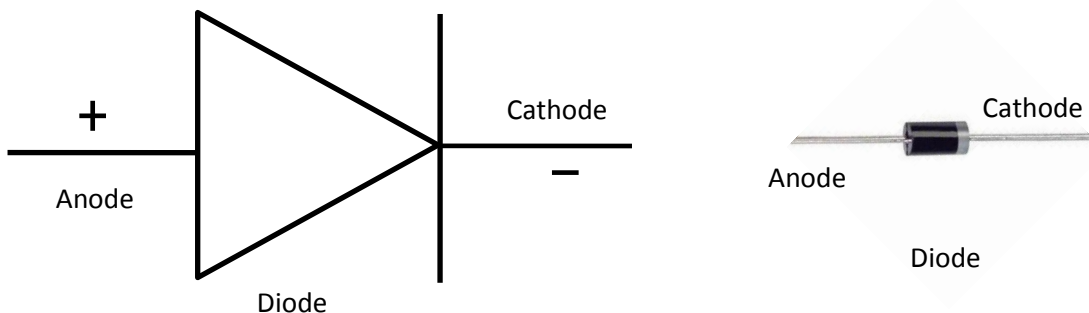

A diode is forward biased when current flows and reverse biased when no current flows

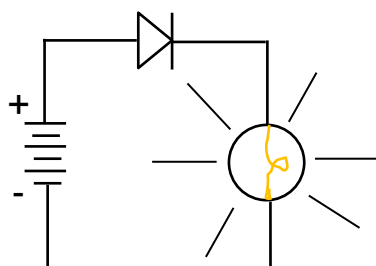

Diode forward-biased  
Current flow, lamp on

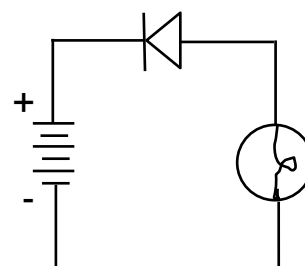

Diode reverse-biased  
No current flow, lamp off

Diodes have a huge range of uses and you will find diodes in many circuits. A very common use of a diode is as a rectifier. (Converts AC to DC)

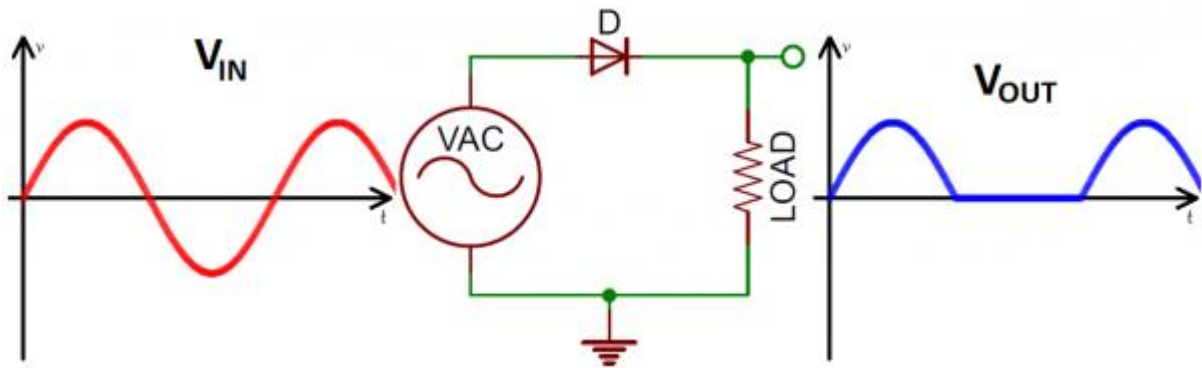

**Notes to lecturer:** Add a diode to the series or parallel circuit. Show what happens to the lamps/LED when the diode is forward biased and then reversed biased.

### 9. Capacitor

A capacitor is a passive electrical component that stores an electrical charge. (Energy) It consists of two electrical plates (conductors) which are separated by an insulator called a dielectric.

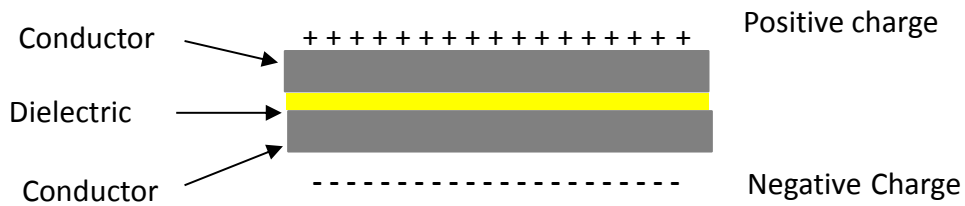

Capacitors are widely used in electronic circuits. Capacitors block DC while allowing AC to flow. They are commonly used to smooth the output of power supplies. In radios, they are used to tune circuits to a particular frequency.

### Symbols

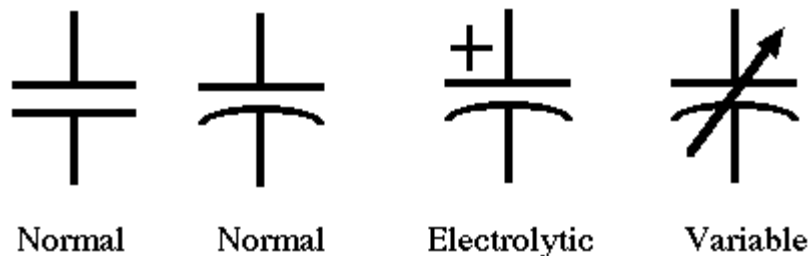

The amount of electrical energy that a capacitor can store is called capacitance. Capacitance is measured in farads, and we use the symbol F. If we relate capacitance to a bucket of water, the bigger the bucket the more water it can hold and hence the bigger the capacitor, higher capacitance, the more energy it can store. Capacitors come in various sizes, types and colours.

Capacitors are charged by wiring it to a DC circuit such as a battery. Never charge a capacitor using AC current. Capacitors can store low voltages to extremely high voltages, so never touch a high voltage capacitor unless it has been completely discharged.

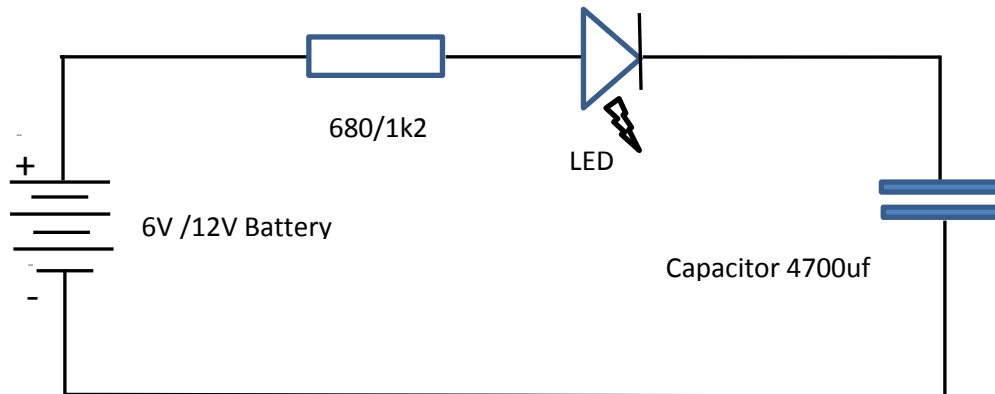

**Notes to lecturer:** The students can build the above circuit. For wiring, use crocodile clips. When closing the circuit the LED will light up and then gets dimmer as the capacitor charges up. Once the capacitor is fully charged the LED will go off.

### 10. Inductors:

An inductor is a passive electrical component that resists electrical current flowing through it and stores energy in the form of a magnetic field. An inductor consists of a conductor (normally copper wire) that is wound into a coil. When a voltage flows through the coil, the energy is temporarily stored in the magnetic field around the coil. When the current in the coil changes direction, the collapsing magnetic field induces a voltage in the coil.

Inductance is measured in Henrys and is abbreviated with an H and uses a symbol of L for calculations. Typical values would be mH or  $\mu$ H.

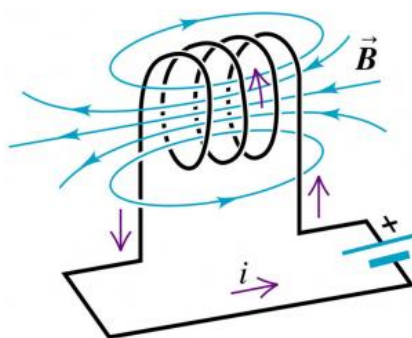

**Self-Induction**

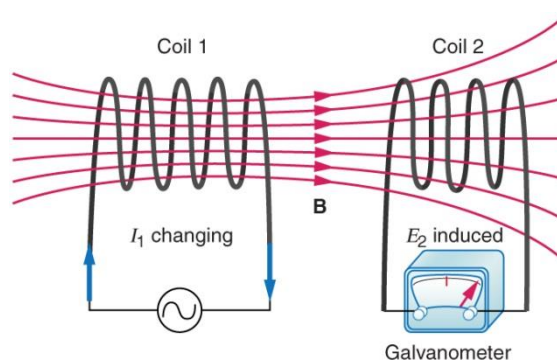

**Mutual Induction**

### **10.1 Self-induction**

If a steady current flows through a conductor, it will produce a constant magnetic field around the conductor, this is called self-inductance.

**Notes to lecturer:** Make a simple electromagnet to show self-inductance.

Items required:

1. Copper wire
2. Steel nail
3. Battery

Wind the copper wire around the nail and then connect the two ends to the battery terminals. Once the current starts to flow, a magnetic field will be created turning the nail into an electromagnet. You should be able to pick up a few paper clips with the electromagnet. The magnetic field strength will increase with more turns and a higher voltage battery.

### **10.2 Mutual Induction**

When an alternating current flows through a coil, an alternating magnetic field is produced around the coil. When another coil is placed within this alternating magnetic field, it generates a voltage in the second coil, this is called mutual inductance.

In simple terms, mutual inductance occurs when the changing current in one coil, induces a voltage in an adjacent coil.



## Chapter 6

### Radio Communication Principles

#### 1. Crystal Radio Receiver (not for exam purposes)

A crystal radio receiver is the simplest form of a radio receiver, and was very popular in the early 1920's to the 1930's. During these times, it was a magical experience, listening to voices and music from far away stations without using wires.

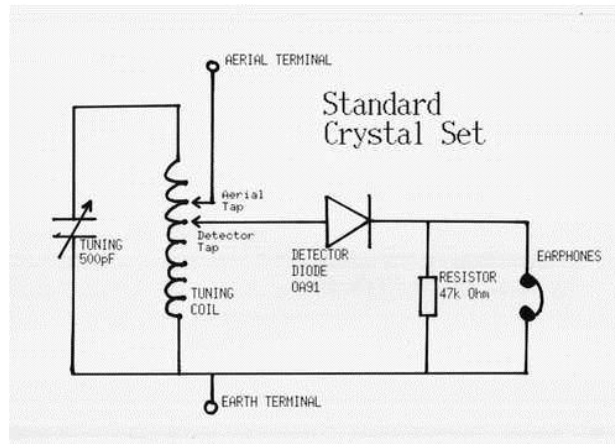

The crystal radio consists of a tuning capacitor, tuning coil, detector diode, and a high impedance or crystal head set.

Being a very basic and simple design, it is difficult to separate stations from each other. This means that you will often hear other stations in the background. This is due to the lack of selectivity. To increase selectivity, you can add a tuning capacitor of 10pf to 50pf between the antenna and tuning coil.

The tuning capacitor and coil are adjusted for the incoming radio signal frequency. The detector diode then converts the radio signal into an electrical signal which then gets converted into an audio signal via the headphones.

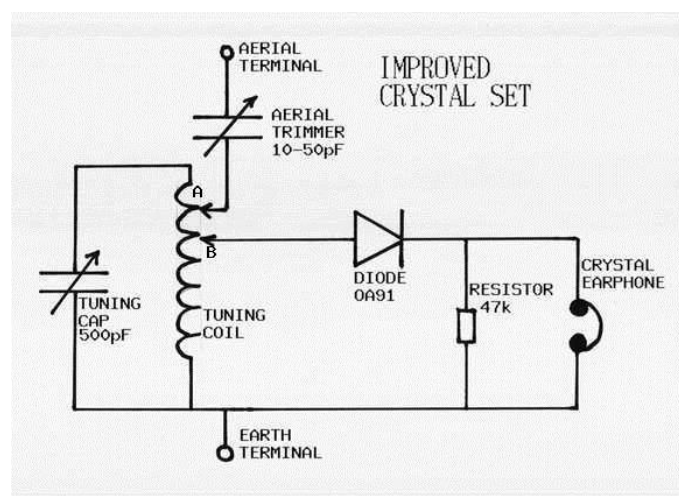

The tuning coil consists of between 50 to 100 turns of 0.3mm to 0.4mm enamelled copper wire, with a tapping every 10 turns. Use a nonconductive core of between 40mm to 70mm diameters.

## 2. Power and dBW (Decibel Watt)

The **decibel watt** or **dBW** is the unit of measurement for the strength of a signal expressed in decibels relative to one watt.

The formula is stated as:

$$\text{Power in dBW} = 10 \log_{10} \frac{\text{Power}}{1\text{W}}$$

A “Class B” student is not required to learn the formula, but should know that he/she may only use a maximum power of 20 dBW which is equal to 100 watts on the HF bands.

**Table A**

Decibel Watt	Watt
0 dBW =	1 W
3 dBW =	2 W
6 dBW =	4 W
9 dBW =	8 W

**Table B**

Decibel Watt	Watt
10 dBW =	10 W
20 dBW =	100 W
30 dBW =	1000 W

In “Table A” you will see that 0 dBW is equal to 1 W. 3 dBW is equal to 2 W and 6 dBW is equal to 4 W. 9 dBW is equal to 8 W. From this table, we can see that for every 3 dBW the power in watts doubles.

In “Table B” you will see that 10 dBW is equal to 10 W. 20 dBW is equal to 100 W and 30 dBW is equal to 1 000 W. From this table, we can see that for every 10 dBW the power is increased by 10 times.

According to current band planning, a Class B licence holder may use a maximum output power of 20dBW, on the HF bands. From the above table we can see that this is equal to 100 W.

### 3. Modulation

Modulation is the process of varying the properties of a wave form. In radio communication we are mainly concerned with Amplitude Modulation and Frequency Modulation.

#### Sine Wave

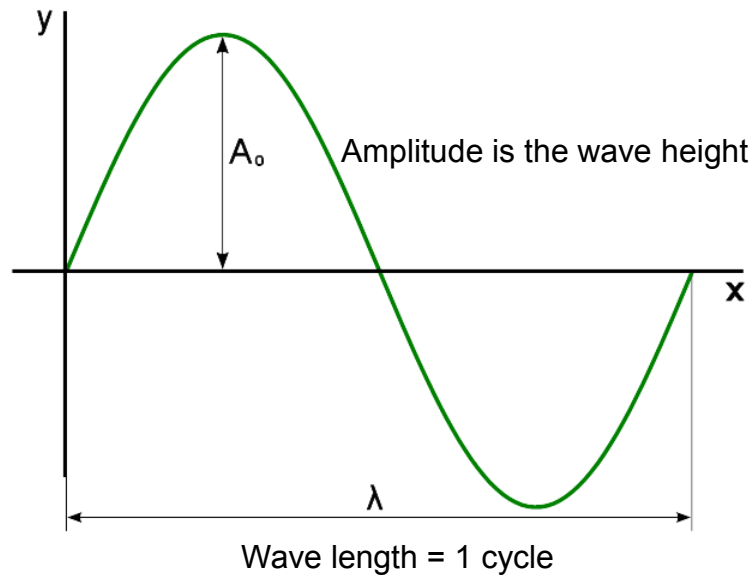

Frequency is the number of cycles per second and is measured in Hertz. Symbol = **Hz**

### 4. Amplitude Modulation

The amplitude varies while the frequency remains the same.

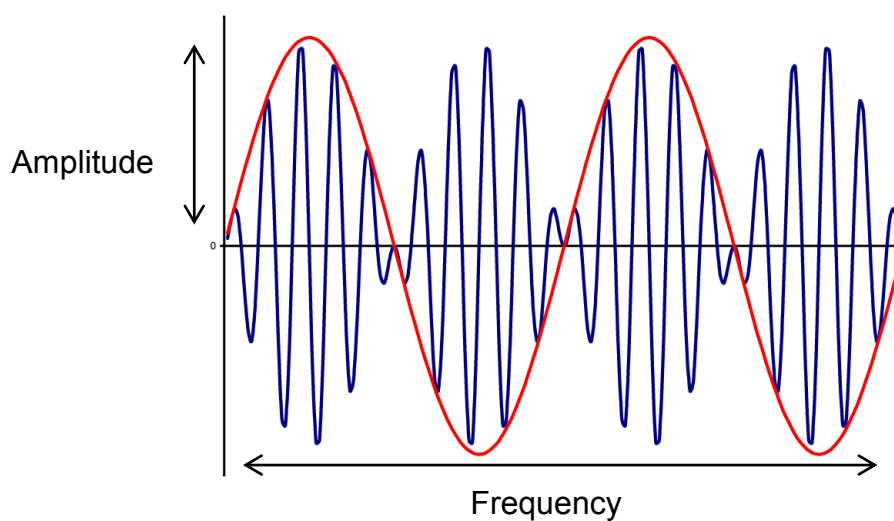

### 5. Frequency Modulation

The frequency varies and the amplitude stays constant.

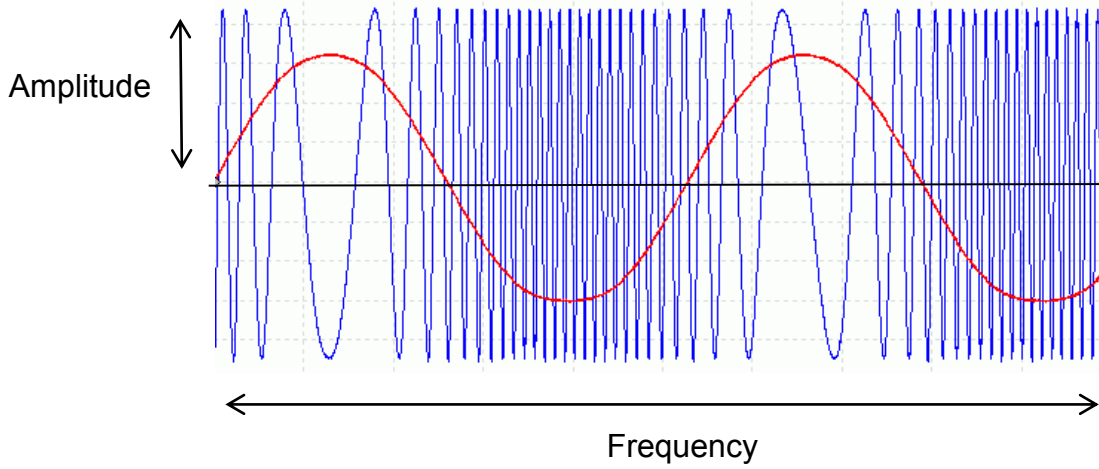

### 6. Single Side Band (AM)

Here we either use the upper section or the lower section of the amplitude. The lower section, LSB is used for frequencies below 10 MHz. The upper section, USB is used for all frequencies above 10 MHz.

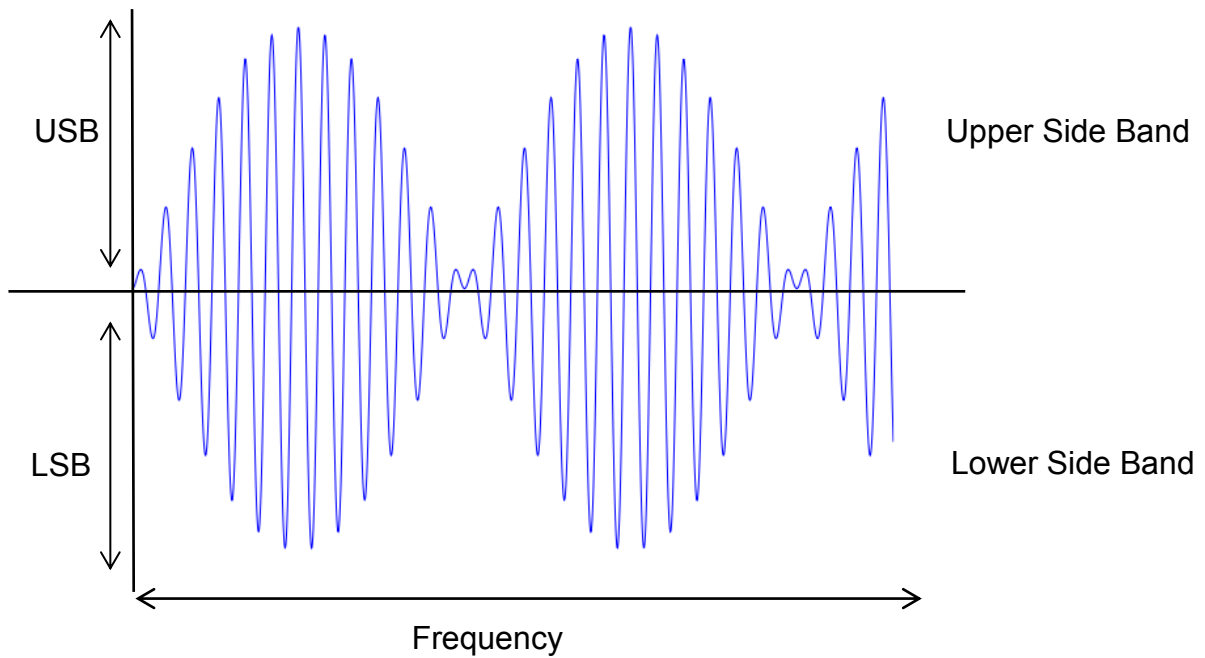

## 7. Frequency and Wave length

The speed of light travels at approximately 300 Million metres per second. Radio waves travel at the same speed. If we want to work out the wave length then we use the following formula:

$$\text{Wave length } \lambda = \frac{\text{Speed of light in Mega m/s}}{\text{Frequency in MHz}} \quad \lambda = \text{Lamda}$$

### Examples:

Class B license holders are allowed to work on the following HF (high frequency) bands:

80m band - 3.50 to 3.80 MHz, so this is equal to a wave length of 80 metres.

40m band - 7.00 to 7.200 MHz, so this is equal to a wave length of 40 metres.

10m band - 28.050 to 28.150 MHz, so this is equal to a wave length of 10 metres.

10m band - 28.300 to 28.500 MHz, so this is equal to a wave length of 10 metres.

## Chapter 7

### Antennas

An antenna is a device that converts electrical energy into radio waves and in turn converts radio waves into electrical energy. An antenna consists of an arrangement of electrical conductors that are connected to a transmitter and or a receiver. Antennas come in various forms, shapes and sizes.

#### 1. How Antennas work

An alternating current (radio frequency) is sent to the antenna (conductor). The radio frequency creates a varying magnetic field around the conductor. The magnetic field in turn induces an electric field around the conductor. This continuous process of varying the electric and magnetic fields produce waves, called Electromagnetic **Waves**. These **Electromagnetic Waves** are **Radio Waves** and travel at the speed of light.

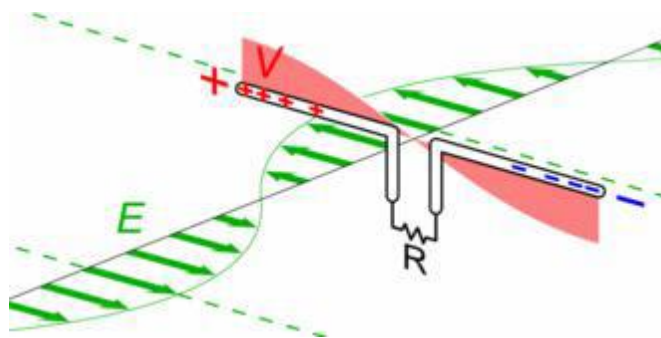

#### 2. Vertical Antenna

A vertical antenna consists of a vertical element that is cut to a certain wave length for the band that it is going to be used on. It also has a few ground radials that act as the other half of the antenna. These radials should be cut to the same wave length as the vertical element.

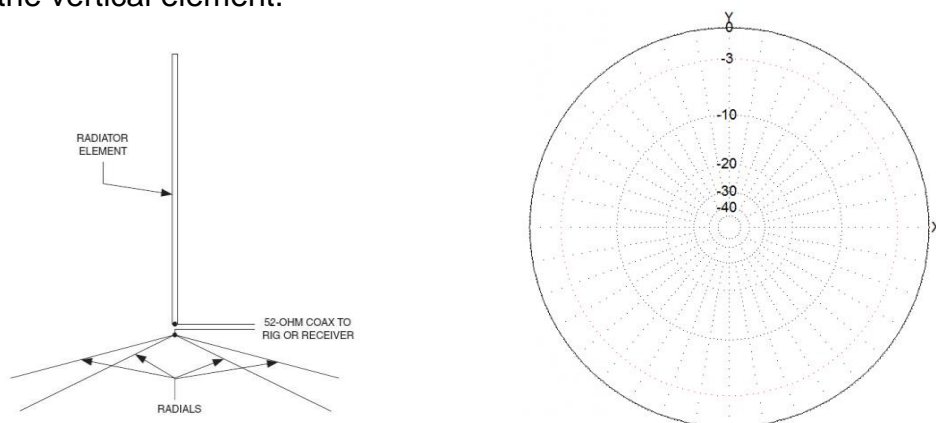

### 3. Dipole Antenna

A dipole antenna consists of two identical conductive elements placed end to end on the same axis. A feed line connects the two elements together in the centre. The most common form, is that each elements is a  $\frac{1}{4}$  (quarter) wavelength, making the antenna a half wave dipole.

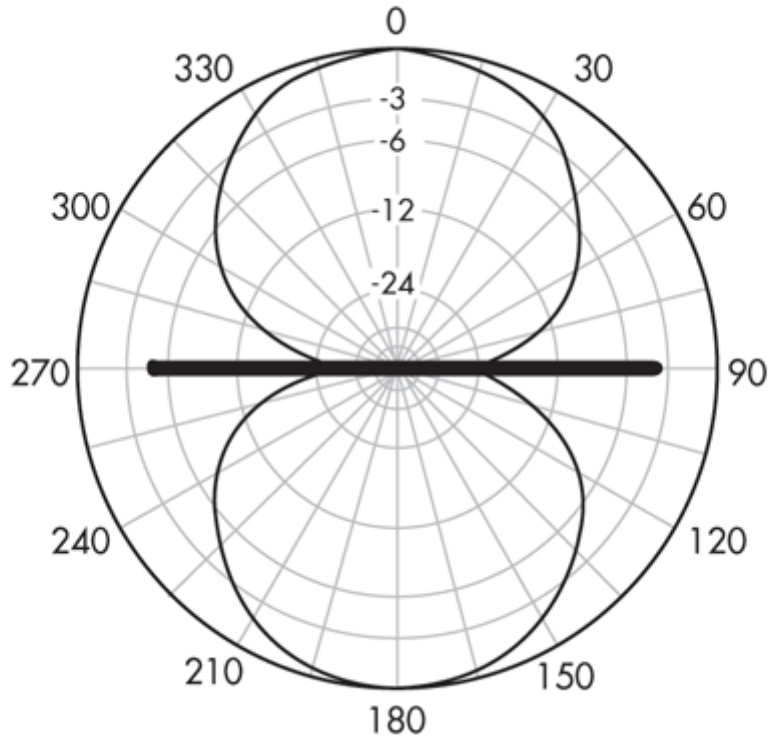
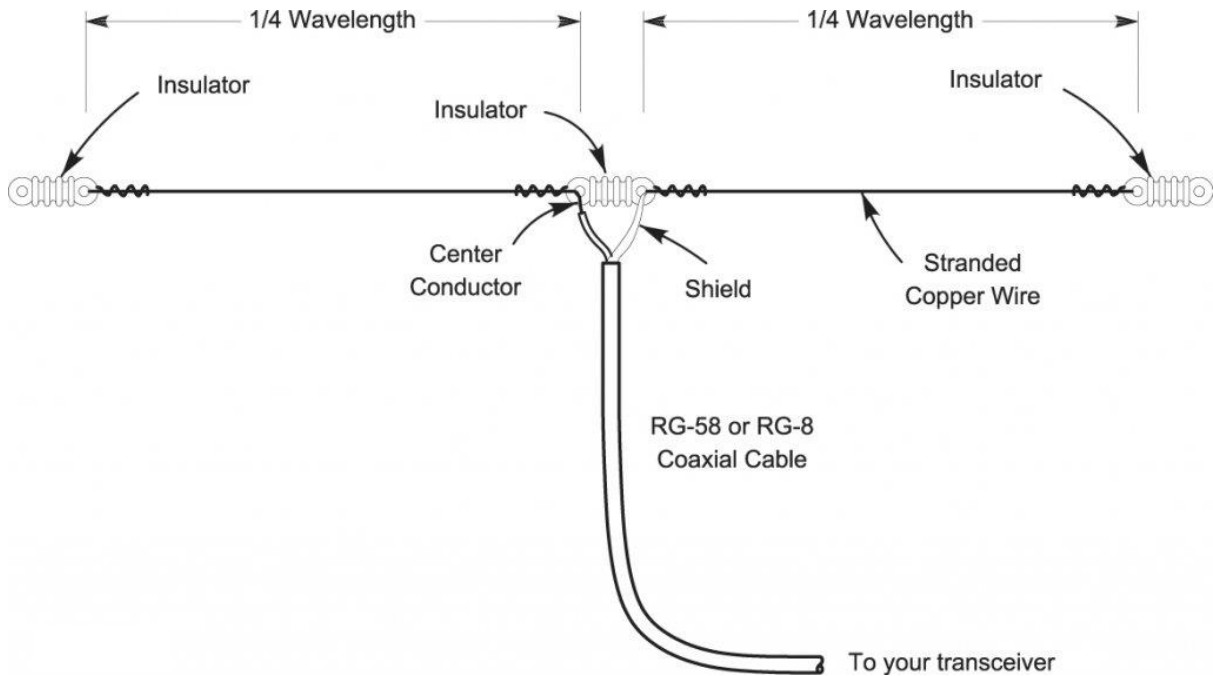

Radiation pattern of a half wave dipole - top view.

#### 4. Yagi Antenna

A Yagi antenna is a directional antenna consisting of multiple parallel elements. A Yagi antenna is made up of a driven element which is connected to the transmitter or receiver and a reflector and or multiple director elements. The reflector element is slightly longer than the driven element while the director elements are shorter. This makes the Yagi a directional antenna.

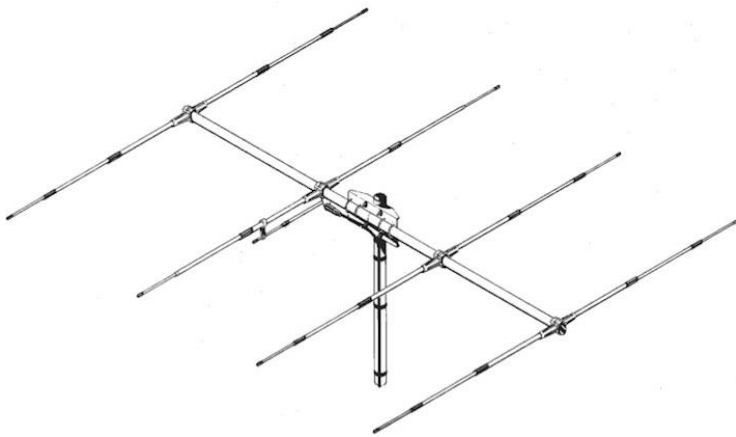

Yagi Antenna

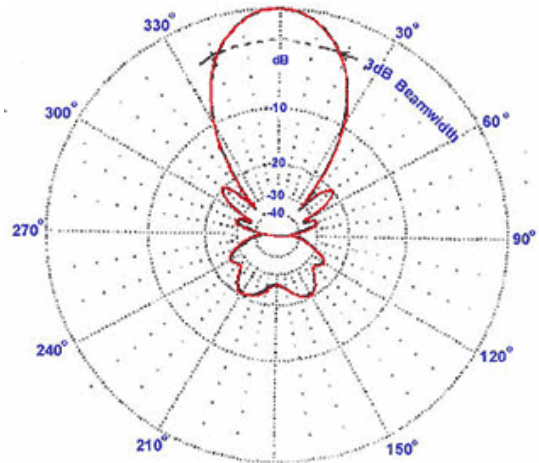

Radiation pattern - top view

#### 5. SWR (Standing Wave Ratio)

SWR is a measurement of how much power is reflected from the antenna. The minimum reflected power is 1.0. This means that all the power from the Transmitter is reaching the antenna and no power is being returned. If there is a high SWR, say of more than 3.0, it means that a large portion of the power is being returned to the transmitter. This indicates that the antenna or connection to the antenna is not correctly set up for the frequency or band used.

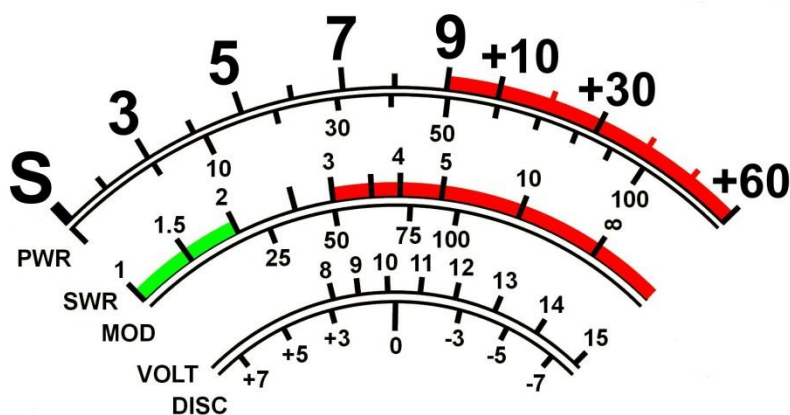

In the above image, the green on the SWR scale represents a good SWR and the RED poor SWR.



## 6. Dummy Load

A Dummy load is a device that is connected to the transmitter in place of the antenna and allows the transmitter to transmit, without sending out a radio signal. A dummy load is mainly used for testing purposes or for tuning a radio transmitter to a certain frequency without transmitting a radio signal.



## Chapter 8 Propagation

Propagation is how radio waves travel through the atmosphere when they are transmitted from one station to another.

### 1. Main types of radio propagation are:

- a) Direct waves
- b) Ground waves
- c) Sky waves

#### a. Direct Waves

Direct Waves travel in a straight line from the transmitter to the receiver. In order for this to happen, the two antennas should ideally have a direct line of sight between each other. The maximum line of sight or distance between the two antennas depends on the height of each antenna. Hilltops or tall buildings always provide the best coverage, but this still limits the range to about 80km, due to the earth's curvature.

Communication with Satellites and the Space Station are also done via direct wave propagation.

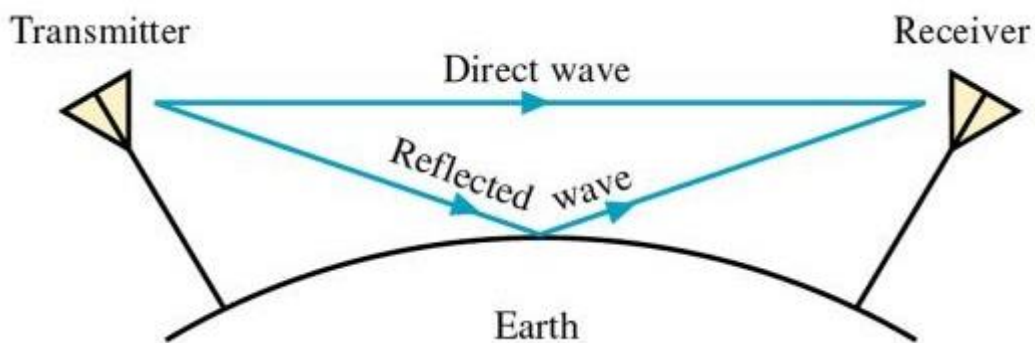

#### b. Ground waves

Ground waves travel along the surface of the earth. These are low and medium frequency waves under 2MHz. These waves hug the Earth's surface.

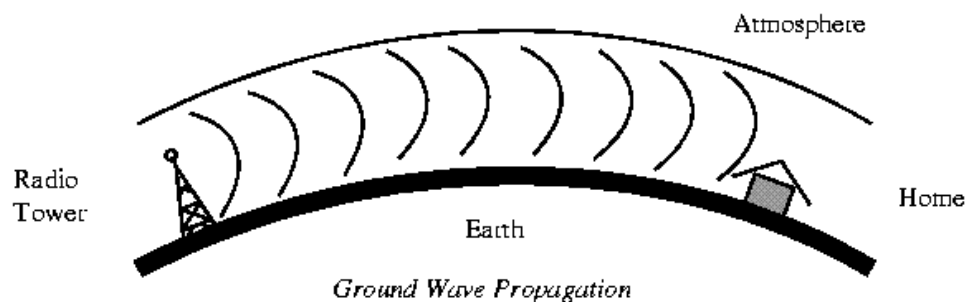

### c. Sky Waves

Sky waves are radio waves that travel to the Ionosphere (the layer surrounding the earth's atmosphere) and in simple terms, these waves get reflected back to the Earth. In turn, the Earth can also reflect these waves back to the Ionosphere, generating multiple "hops" therefore the waves are able to travel a longer distance. Certain factors influence the reflection of radio waves like frequency, day time, night time, sun spot activity and weather conditions.

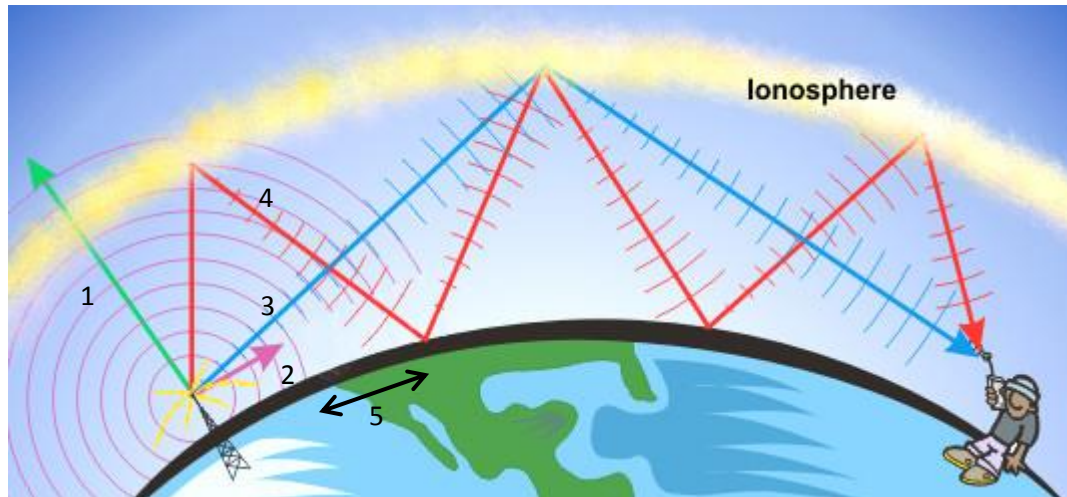

1. Direct wave penetrating the atmosphere
2. Ground wave
3. Sky wave
4. Sky wave multiple hops
5. Skip zone

### 2. Skip Zone

The skip zone is a region where the radio signal or transmission cannot be heard. This is the region between the farthest points of the ground wave which can be received and to the nearest point at which the reflected wave can be received.

## Chapter 9

### Electromagnetic compatibility and interference

#### 1. EMC (Electromagnetic compatibility)

EMC is concerned with the shielding and limiting of electromagnetic activity to ensure that radio transmitters or any other equipment that radiate electromagnetic waves, do not interfere with electrical or electronic devices like TV's and other radio receivers or transmitters.

Strict guidelines concerning EMC are implemented by the authorities, and all electrical and electronic equipment should comply. Equipment should limit radiation to an acceptable level, thereby avoiding interference with other devices.

#### 2. EMI (Electromagnetic interference)

Electromagnetic interference is unwanted electromagnetic radiation that may cause interference to other electrical or electronic equipment.

**EMI can be divided into two categories:**

**Continuous interference:** Continuous interference is *often* in the form of a constant oscillating radio signal. It may be from an unscreened oscillator, which creates noise. Examples: an electrical fence, switching power supplies and unfiltered radio signals.

**Impulse interference:** This form of interference consists of a short impulse. Example: an electrostatic discharge, lightning, or a circuit being switched.

Note: To avoid interference, equipment should be used according to the manufacturer's specifications and should not be altered. All radio equipment should be correctly grounded (earthed).

